



MT 900-TA

165.08



# Tenders + Spreaders

**PRODUCT INFORMATION GUIDE**

40.93  
TRAILER TO  
GROUND

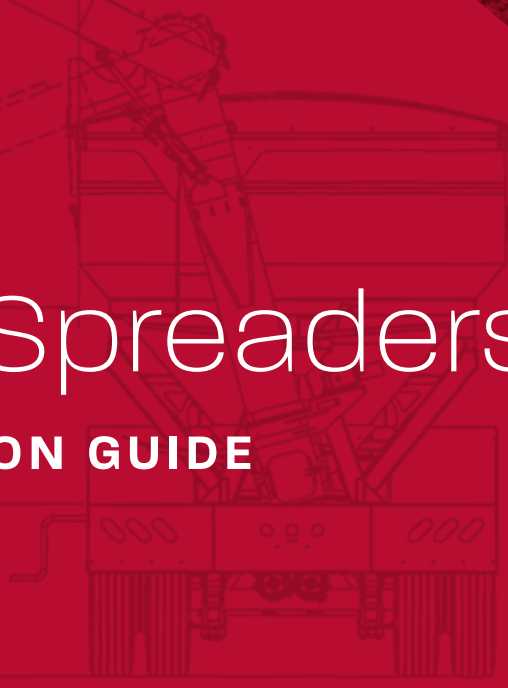

# Tender Series

## Tending to your bottom line.

When it comes to tight deadlines and maximizing productivity, every angle matters. The complete Tender Series from Heartland AG Systems features the most innovative design in the industry. Built for faster unload times, better product flow and enhanced safety, this line of tenders features up to 50° angled hopper bottoms, 270° swivel auger and 360° solutions you can rely on load after load.

**Models:**  
**MT900-TA**  
**MT700-TA**  
**MT600-TA**  
**1612**  
**MT 32**  
**MT 24**  
**MT 16**  
**MT 10\***



Built to solve your biggest fertilizer delivery needs with less effort.

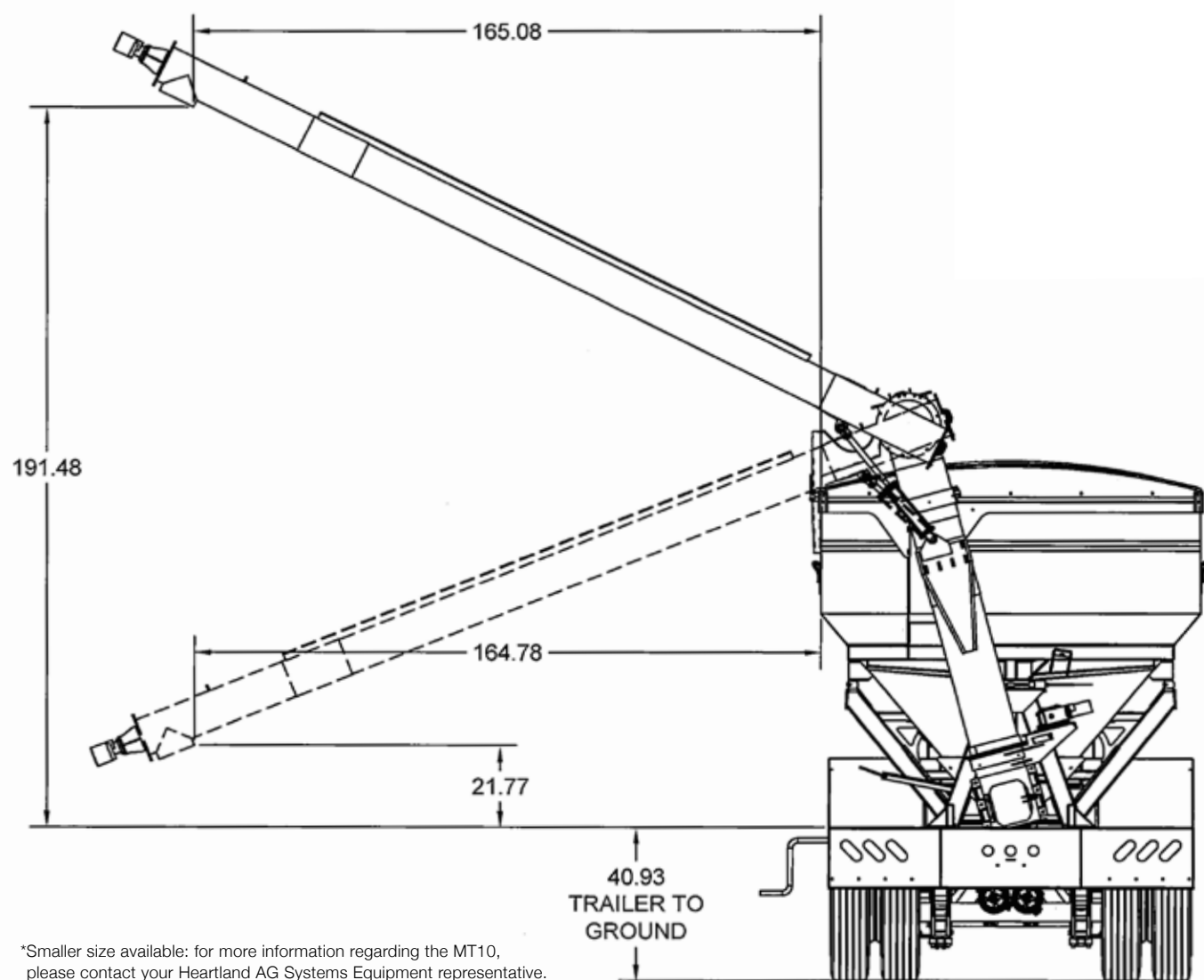

\*Smaller size available: for more information regarding the MT10, please contact your Heartland AG Systems Equipment representative.

- Unload Rates Up to 4,500 lbs. per Minute
- Self-Cleaning Bins
- 304 Stainless Steel Construction
- 50° Angled Hopper Bottom
- Low Center of Gravity
- 270° Swivel Auger
- Diesel Engine or Wet Kit

- Better product flow and faster unloading
- Product viewing windows to easily see what's happening inside
- Built strong for tough road conditions
- Extended discharge heights
- Less maintenance, lower costs
- No shoveling, less downtime

### MT900-TA

- Top Unload 28 Ton Tender
- Struck Capacity: 900 cu. ft.
- 6 Compartments

### MT700-TA

- Top Unload 21 Ton Tender
- Struck Capacity: 700 cu. ft.
- 4 Compartments

### MT600-TA

- Top Unload 18 Ton Tender
- Struck Capacity: 600 cu. ft.
- 4 Compartments

### Additional Options:

- Trailer Mounted or Truck Mounted
- Engine Driven or Hyd. Quick Coupler Pkg
- SRT Electric Roll Tarp
- Scale Package

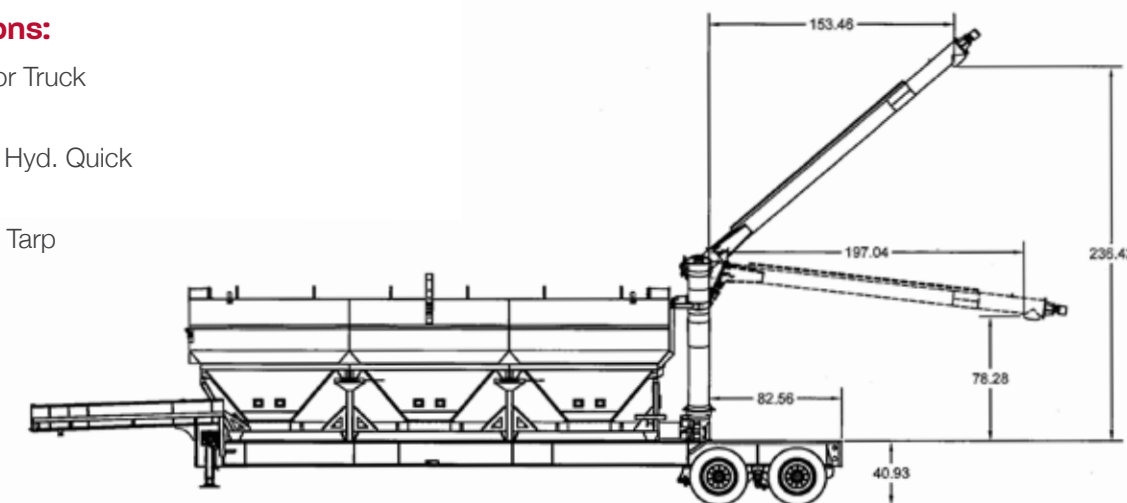



Keep your operation moving forward with rugged durability and quality.



### MT 16 Tender

A cost-effective tender solution designed to solve all of your bulk delivery problems.

- Unload Rates Up to 3,500 lbs. per Minute
- Large Clean-Out Doors Under Each Hopper
- Rear Clean-Out Door
- Unitized One-Piece Body Construction with 409 or 304 Stainless Steel.
- 40° Hopper Bottom
- Low Center of Gravity
- Less Pump and PTO

#### Additional Features:

- Front and Rear Ladders
- Viewing Window
- Wiring harness with LED lights
- Hydraulic Folding and Raising Auger (Discharge 96 to 142 in. (244 To 361 cm) from Base)
- 8 in. (20 cm) Horizontal Unloading Auger to the 10 in. (25 cm) Rear Mounted-Side Unloading Auger
- Mud Flaps, S.S. Fenders, DOT Lights
- Optional: Hopper Vibrators
- Optional: Stainless Steel Arched Divider

Maximum performance to move more product faster.

### 1612 Tender

#### 16 Ton Rear Discharge Tender

- Unload Rates Up to 5,500 lbs per Minute
- Large Cleanout Door
- Struck Capacity: 500 Cubic Foot
- 409 or 304 Stainless Steel Construction
- 41° Side Slope
- 36° End Slope
- 2 Compartment Hopper
- 12" S.S. Discharge Auger
- Hydraulic Drive
- Tarp Options: Manual or Electric Roll
- 409 Stainless Steel Painted White
- Stainless Steel Slide Gates
- 21-1/2' x 12" Stainless Tube & Screw
- Mud Flaps, S.S. Fenders, DOT Lights



FEATURES	MT24	MT16	MT32
Capacity: cu. ft. (cu. meters.)	771 (21.8)	514 (14.55)	1,028 (29.1)
Body	Six separate 409 stainless hoppers with six individual control gates	Four separate 409 stainless hoppers with four individual control gates	Eight separate 409 stainless hoppers with eight individual control gates
Tare Weight: lbs. (kg)	4,500 (2041)	3,435 (1556)	6,870 (3116)
Auger Reach (Raised): in. (cm)	Min. Height discharge reach: 160" Max. Height discharge reach: 133"	Min. Height discharge reach: 160" Max. Height discharge reach: 133"	Min. Height discharge reach: 160" Max. Height discharge reach: 133"
Discharge Height (Raised) From Frame Base: in. (cm)	142 (361): 16 ft. (488 cm) auger	142 (361): 16 ft. (488 cm) auger	142 (361): 16 ft. (488 cm) auger
Base Dimensions: in. (cm)	34 x 292 (86 x 742)	34 x 196 (86 x 496)	34 x 396 (86 x 1005)
Body Dimensions: in. (cm)	96 x 288 (244 X 732)	96 x 192 (244 x 488)	96 x 388 (244 x 985)
Body Height: in. (cm)	81 (206)	81 (206)	81 (206)
Discharge Auger Size: in. (cm)	10 (25)	10 (25)	10 (25)
Horizontal Auger Size: in. (cm)	8 (20)	8 (20)	8 (20)
Bolt on Extensions: cu. ft.	142	95	190

\*Smaller size available: for more information regarding the MT10, please contact your Heartland AG Systems Equipment representative.

# Spreader Series

## Built and assembled by the application experts.

The AG Spreader Series by Heartland AG Systems Equipment is designed for those who value safety and durability. Built for years of rugged use and the tough demands of fertilizer application, these spreaders meet the need with one-piece stainless-steel construction and adjustable wheel tracks. Spreading season can look different to every operation, so when you're looking for a compact solution to get the job done right, or provide your growers with a versatile and accurate do-it-yourself solution, look no further than the AG series.

### Models:

AG X10

AG 800

AG 600

AG 500\*

AG 400\*

AG 800-HC

AG 600-HC



It doesn't get any easier than this.

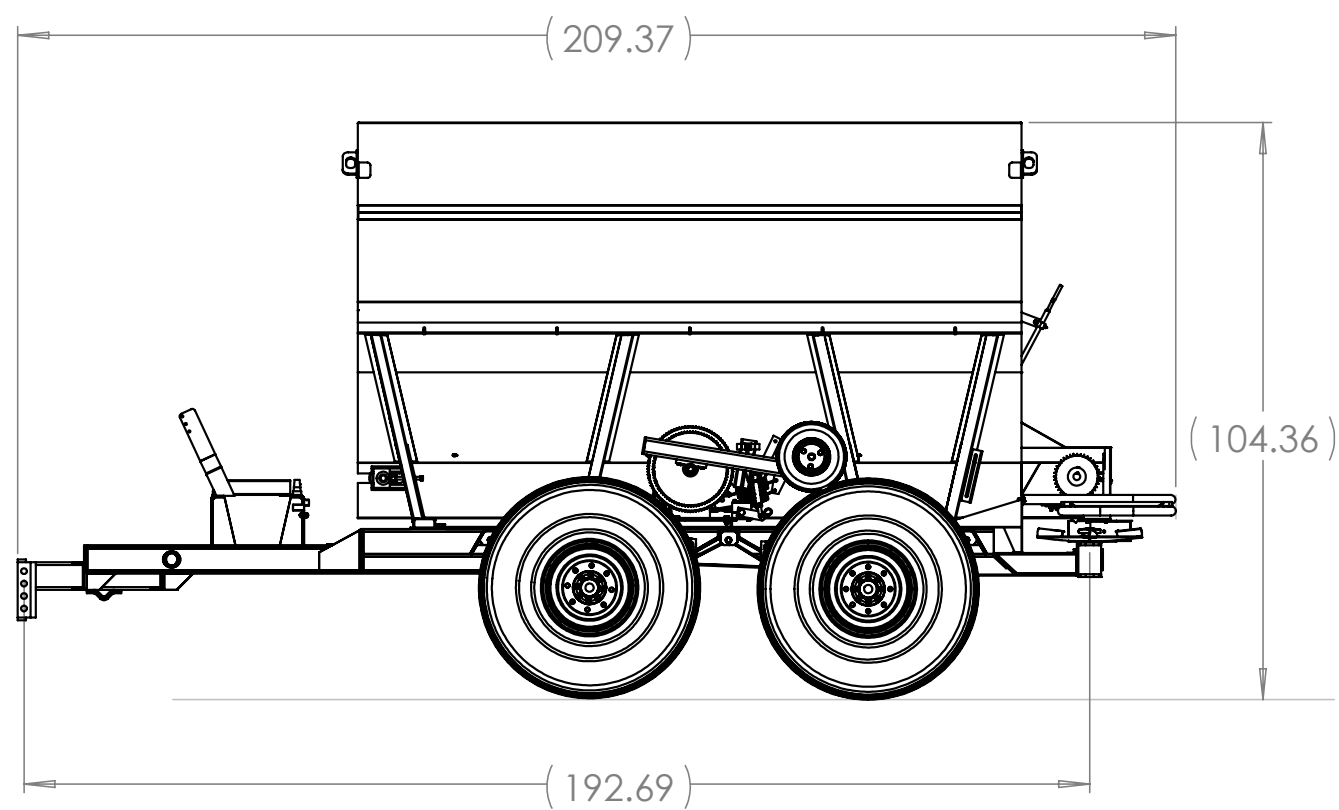

\*Smaller sizes available: for more information regarding the AG 500 and AG 400, please contact your Heartland AG Systems Equipment representative.

## Maximum flexibility with a smooth and efficient spread pattern.

### AG X10

The AG X10 is an adjustable wheel track spreader that features a high-grade 304 stainless steel unitized one-piece body construction. Conveyor trough, metergate, rear skid section, gearbox mounts, line shaft shield and roller chains are also constructed of 304 stainless steel for longer durability.

- Capacity: 10 Ton (312 cu. ft.) Struck
- Stainless Steel Gearbox Mounts

- Two-Speed Conveyor Drive or 540/1000 RPM PTO Spinner Drive
- Your Choice of Single 24" or Dual 19" Distributor
- Heavy-Duty Hitch with Adjustable Clevis
- Stainless Steel Frame Fliptop, Roll Tarp with SS Fitted End Caps and Tarp Options
- Rope Trip Drive or Hydraulic Press Wheel Drive
- Standard 4-Wheel Surge Brakes
- 19L x 16.1 Tire or 11" x 22.5 Highway Tires
- Adjustable Wheel Track of 64" to 78"/ 72" to 88"
- Heavy-Duty 24,000 lb. Leaf Spring Suspension
- 14" Axle Clearance
- 24,000 lb. GWW
- High Clearance Option Also Available

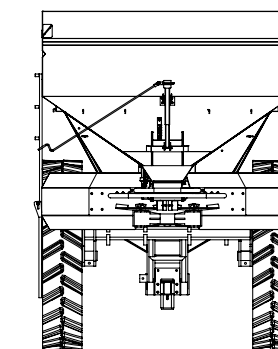
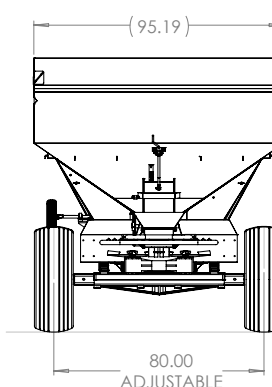
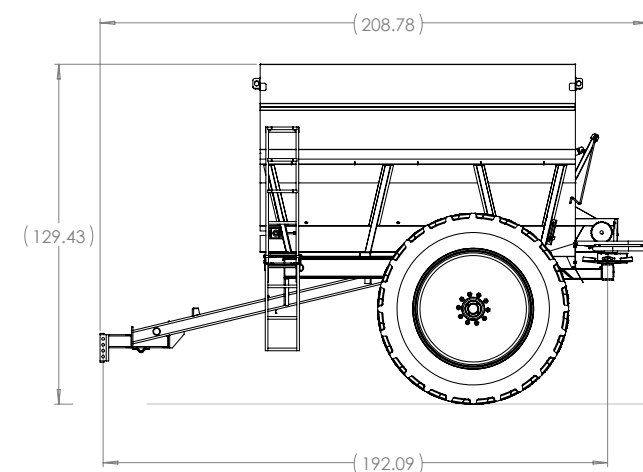



Heavy-duty durability, precise fertilizer application.

## AG Series

### Adjustable Wheel Track Spreader

Our adjustable wheel track spreaders provide years of rugged use. These spreaders feature a high-grade 304 stainless steel unitized one-piece body construction. Conveyor trough, metergate, rear skid section, gearbox mounts, line shaft shield and roller chains are constructed of 304 stainless steel for longer durability.

- Exclusive Design of Jig-Built Box and Trailer with Box Bolting to Trailer
- Stainless Steel Gearbox Mounts
- Two-Speed Conveyor Drive
- Your Choice of Single 24" or Dual 19" Distributor
- Heavy-Duty Hitch with Adjustable Clevis
- Stainless Steel Frame Fliptop or Roll Tarp, with SS Fitted End Caps, Options Available
- 540/1000 RPM PTO Spinner Drive Standard, with Gas-Engine, or Hydraulic Drive Optional
- Optional 11" x 22.5" Highway Tires (other options available upon request)

### AG 800 Spreader

- Adjustable wheel track of 64" to 78"/ 72" to 88"
- Heavy-duty 24,000 lb. leaf-spring suspension
- 14" axle clearance
- Standard 4-wheel surge brakes

### AG 600 Spreader

- Adjustable wheel track of 60" to 78"/ 70" to 88"/ 69" to 90"
- Heavy-duty 16,000 lb. leaf-spring suspension
- 18" axle clearance

\*Smaller sizes available: for more information regarding the AG 500 and AG 400, please contact your Heartland AG Systems Equipment representative.

Extended seasonal usage with optimal durability and even distribution.

## AG HC Series

### High Clearance Adjustable Wheel Track Spreaders

Our adjustable wheel track high-clearance spreaders feature 304 stainless steel box, conveyor trough, metering gate, rear skid section, gearbox mounts, line shaft shield and roller chains are constructed of stainless steel for longer durability.

- Exclusive Design of Jig-Built Box and Trailer with Box Bolting to Trailer
- Stainless Steel Gearbox Mounts
- Your Choice of Single or Dual Spinners
- 42" Axle Clearance
- 2-Wheel Brakes
- Hydraulic Engage press wheel drive or Hydraulic Conveyors drive with ISO control
- Stainless Steel Frame Fliptop or Roll Tarp, with SS Fitted End Caps, Options Available
- 540/1000 RPM PTO Spinner Drive Standard, with Gas-Engine, or Hydraulic Drive Optional
- Standard Sight Window & Optional Ladder

### AG 800-HC Spreader

- 8 Ton (246 cu. ft.) Struck
- Unitized 304 Stainless Steel Box
- 10" SS Apron Chain
- 60' Spread Pattern
- 380/90R46 Tires and Rims
- Adjustable Wheel Track of 80" to 120"/ 88" to 144"
- Heavy-Duty 10 Bolt Hubs
- Heavy-Duty Pole Jack
- 20,000 lb. GWW

### AG 600-HC Spreader

- Capacity: 6 Ton (175 cu. ft.) Struck
- 304 Stainless Steel Box
- Hydraulic Press Wheel Drive and Conveyor
- 320/85R38 Tires
- Adjustable Wheel Track of 80" to 120"/ 88" to 144"
- 4x4 Heavy-Duty Jack
- 16,000 lb. GWW

# Application isn't just our business. It's our everything.

Heartland AG Systems Equipment is your total solutions provider of application support products and accessories tailored to meet the unique challenges of our industry. As a distributor and a manufacturer, we understand the application business and the importance of high quality, durable equipment that produces reliable application performance. Our industry-leading expertise and experience goes into every product we build:

- Tenders
- Fertilizer Spreaders
- Liquid Trailers
- 28% Applicators
- Toolbars
- And more



# Our expertise goes the extra mile.

As the largest Case IH commercial application distributor, we have nine locations across the upper Midwest from which we sell and service our application products.

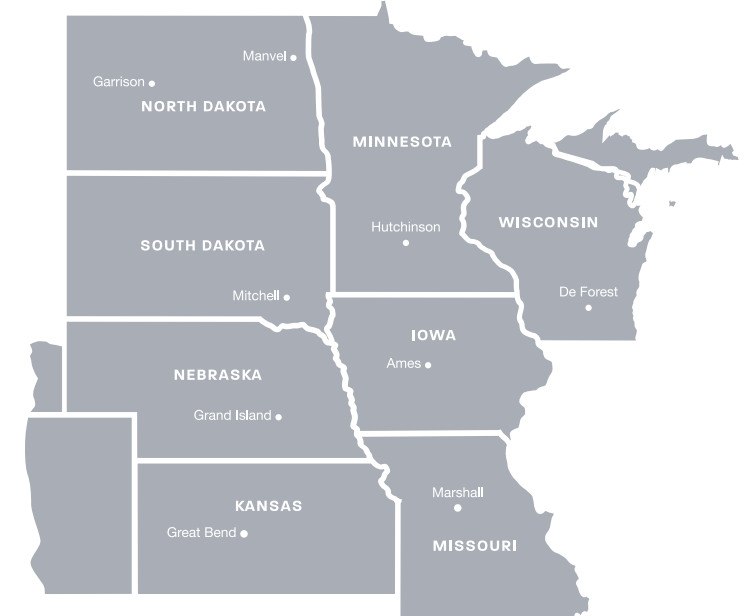

- Ames, IA**
- DeForest, WI**
- Garrison, ND**
- Grand Island, NE**
- Great Bend, KS**
- Hutchinson, MN**  
» Corporate Office  
» Manufacturing Plant
- Manvel, ND**
- Marshall, MO**
- Mitchell, SD**

# We have your application business covered from every angle.

The Heartland AG Systems Equipment team has been working to make application equipment solutions faster, more reliable and safer since 1965. With complete focus on the application industry, our team works day in and day out to solve your toughest application needs so you can achieve the full potential every season brings.

## Efficient

The unique design and engineering of Heartland AG Systems Equipment products delivers a complete portfolio of application solutions, resulting in maximum productivity for superior bottom line performance.

## Reliable

With a reputation built on quality and durability, our products are made with heavy-duty performance to handle long days and tough conditions for the uptime your business demands.

## Safe

Our advanced safety features were designed to provide better equipment solutions that are safer to operate. Safety is fundamental to a successful operation. Which is why, with everything we manufacture, you and your employees stay top of mind.



Every day at Heartland AG Systems, our employees commit to solving your toughest application challenges, all while protecting your uptime. This commitment is what enables us to bring the best possible application equipment, products and services to our customers. When you need informed real-time application solutions, we are the only partner you need.





We are application.

**HeartlandAG.com**  
**Corporate Office &  
Manufacturing Plant**

1180 MN-7  
Hutchinson, MN 55350  
(800)-328-5866

**Ames, IA**  
(800) 779-7979

**DeForest, WI**  
(800) 523-2350

**Marshall, MO**  
(800) 889-6161

**Grand Island, NE**  
(800) 445-9110

**Great Bend, KS**  
(800) 652-9290

**Manvel, ND**  
(800) 582-4269

**Garrison, ND**  
(888)483-7669

**Mitchell, SD**  
(800) 995-1943



Heartland AG Systems