



 **Heartland**
AG SYSTEMS



Heartland
AG SYSTEMS
EQUIPMENT

Liquid Trailers

PRODUCT INFORMATION GUIDE



(88.2)

Liquid Tending Units

Rugged manufacturing and quality performance that's easy and safe to use.

Liquid transport requires durability and flexibility and Heartland AG Systems Equipment delivers with a wide range of tandem liquid tenders that feature rugged construction and easy maneuverability to fit the demands of your operation. As the application experts, we understand high-quality manufacturing that provides long-lasting products to maximize performance is essential for your liquid transportation and application needs.

Models:

AG111

AG116

AG1000

AG1250

SR1000

SC1200

DC3000

TC3000

AG111

Tandem Liquid Tending Unit with Storage Rack

Economical, dependable versatility for all your liquid transportation needs.

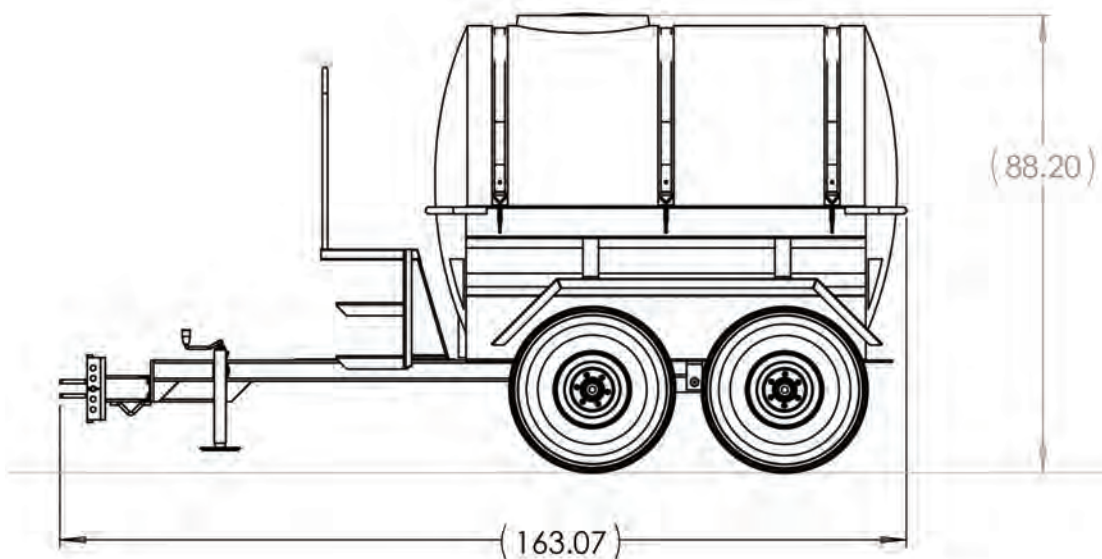



AG116

Tandem Liquid Tending Unit with Storage Rack

Heavy-duty performance for efficient liquid transportation.

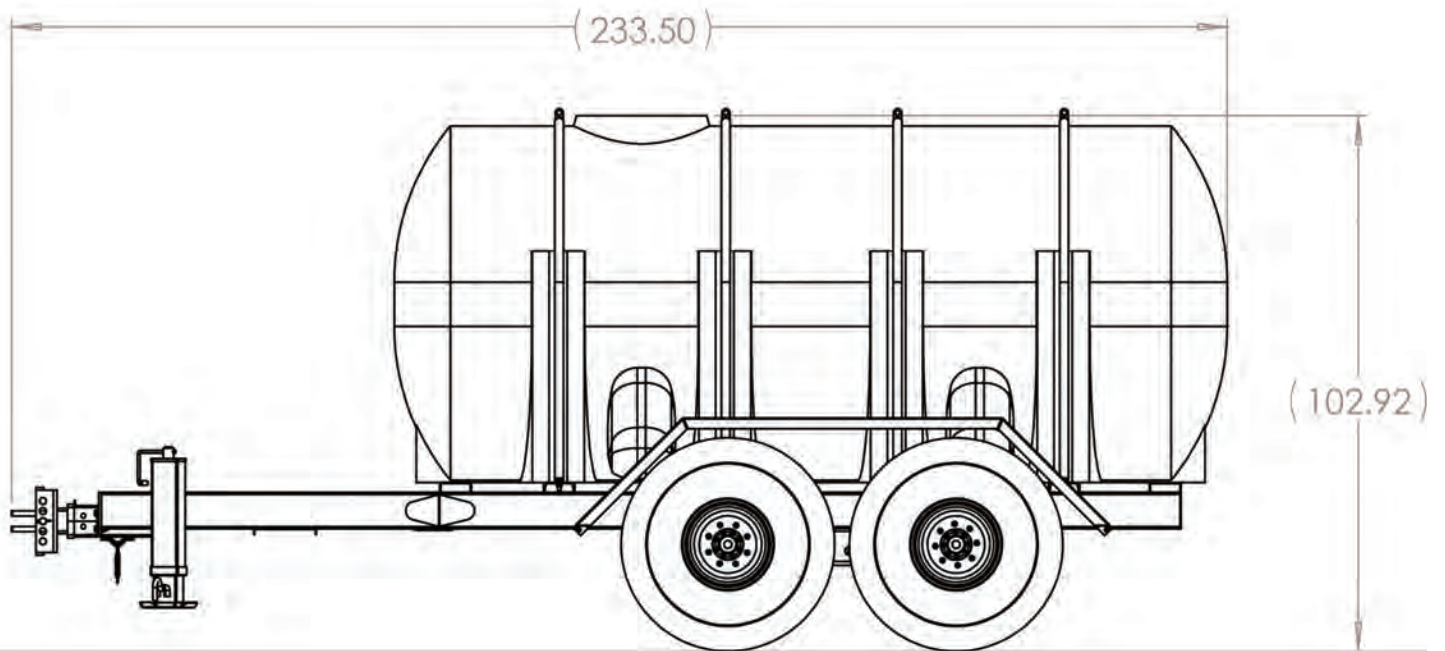

AG111

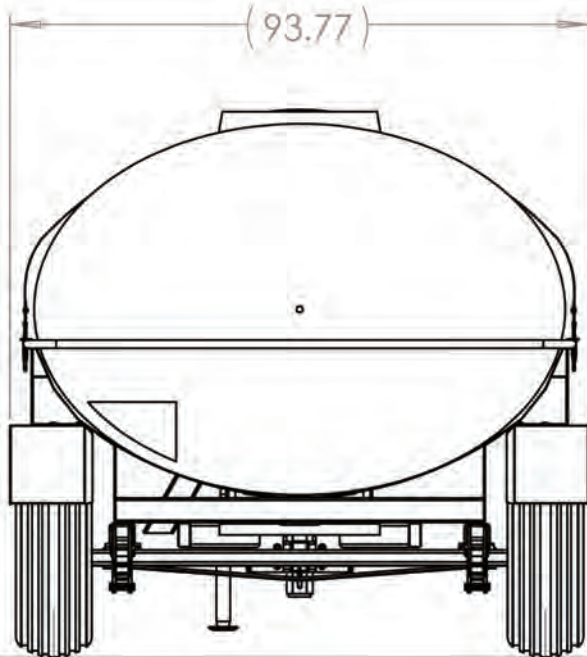

AG116

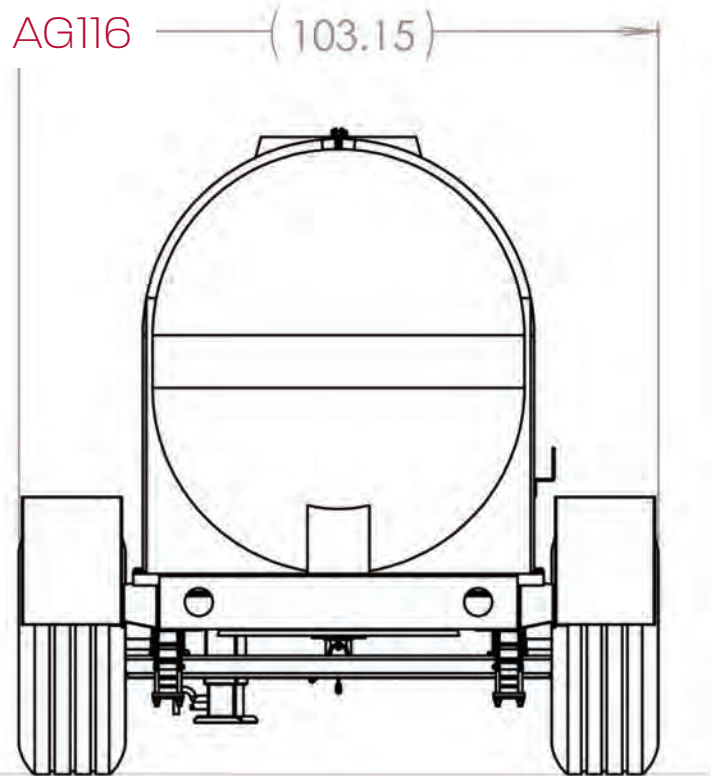

Features

- Axle: Tandem
- Frame: Capped on all ends to prevent inner corrosion
- Liquid System: Tank bolts directly to the frame
- Adjustable Pole Clevis:
 - Allows for level hook-ups
 - 1 1/32" pin hole allows for a full 1" hitch pin
 - Safety chain loop is welded to the pole
 - 3/8" safety chain with grab hooks meets all federal DOT requirements
- The pole is bolted in for easy removal when working on the brake actuator (optional)
- Pump Mount Pad: Standard

Additional Options

- Fenders
- Lights





FEATURES	AG111	AG116
Frame	2" x 4" tubing 1/4" wall, 4" square cross members 3/16" wall	3" x 7" tubing 3/16" wall
	Side frame rails formed of 3/16" steel	N/A
Liquid System	Accommodates a 1,400 gallon elliptical poly tank	Accommodate a 1,685 gallon or 2,000 gallon poly leg tank
	End draining tank sump	Standard flat bottom leg tank Optional: Drainable tank
	N/A	Tank bands are two piece for UPS shipping
	N/A	Allows for better tank expansion
	N/A	Hose hooks provide easy storage
Track Width	80'	86'
Hubs/ Spindles	4500# pound hubs and 2" diameter spindles	6100# pound hubs and 2 3/4" diameter spindles
	6-on-6 hub pattern	8-on-8 hub pattern
Rims	Standard 10" x 15"	Standard 14" x 16.1"
Axle Clearance	13" with 12.5L tires	15" with 16.5L tires
Adjustable Pole Clevis	Replaceable clevis	
	A 2000# top winding Bull Dog jack - Swivels out of the way - Removable	Heavy-duty 4"x4" jack - Quick adjust foot - Swivels out of the way - Removable
Leaf Spring Suspension	7 leaves, .401" thick by 2" wide Heavy-duty rocker arm assembly w/grease-able bolts	6 leaves, .401" thick by 3" wide Heavy duty rocker arm with grease-able bolts
Brakes	Optional	4 wheel surge brakes are standard
GVW	16,000#	24,000#
Options	12 x 16.5 12 ply highway tires	11 x 22.5 new highway tires/rims
	2 5/16" ball hitch package	Optional
	2-wheel and 4-wheel brakes	Optional

AG1000

1,000 Gallon Drainable Liquid Tender with Wagon

The ultimate in heavy-duty construction designed for fast and efficient transportation.

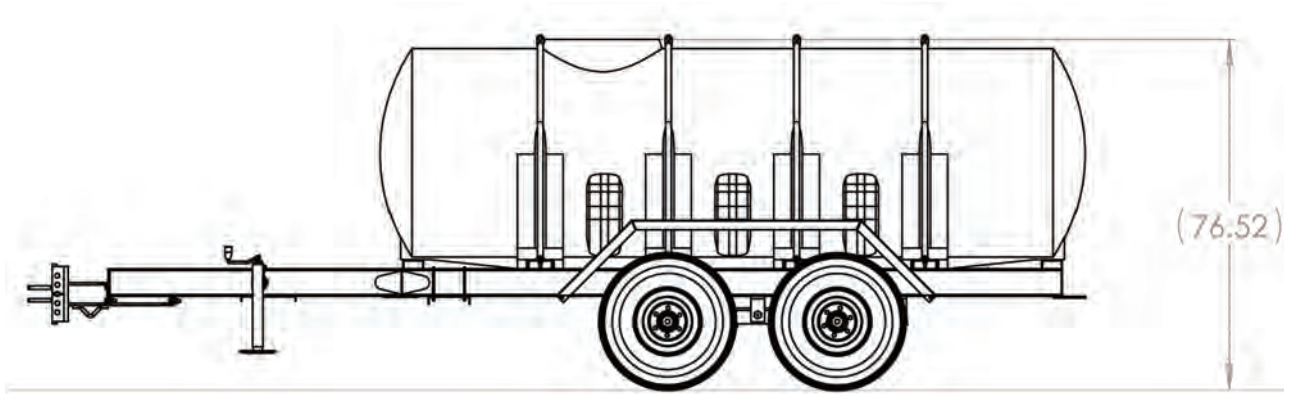

AG1250

1,250 Gallon Drainable Liquid Tender with Wagon

Professional-grade strength for optimal efficiency and rugged durability to handle your biggest jobs.

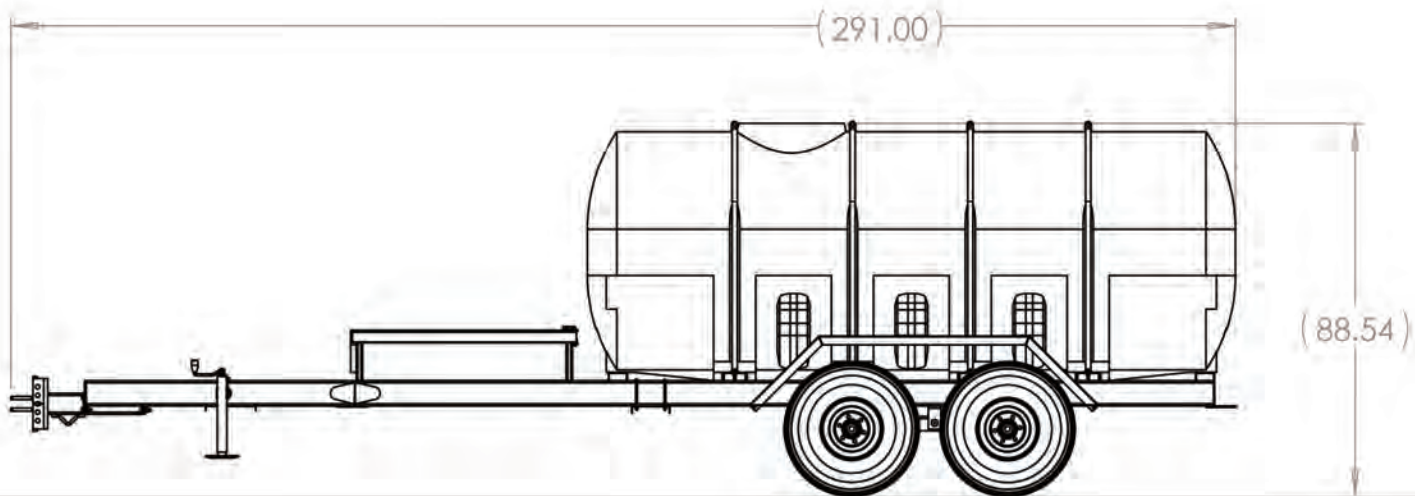

Features

- Axle: Tandem
- Frame: Capped on all ends to prevent inner corrosion
- Liquid System:
 - New drainable tank w/center sump
 - Tank bolts directly to the frame
 - Tank bands are two piece for UPS shipping
 - Allows for better tank expansion
 - Hose hooks provide easy storage
- Track Width: 72"
- Hubs/ Spindles: 6 on 6 hub pattern
- Adjustable Pole Clevis:
 - Wide range of hook-ups
 - 1 1/32" pin hole allows for a full 1" hitch pin
 - Replaceable clevis
 - Safety chain loop is welded to the pole
 - 3/8" safety chain with grab hooks meets all federal DOT requirements
 - "2000# top winding Bull Dog jack
 - Swivels out of the way
 - Removable"
 - The pole is bolted in for easy removal when working on the brake actuator (optional)
- Leaf Spring Suspension: Heavy-duty rocker arm assembly w/grease-able bolts
- Pump Mount Pad: Standard
- Options:
 - Fenders
 - Lights
 - 2 5/16" ball hitch package
 - 2-wheel and 4-wheel brakes
 - Bolt-on step

SR1000

Same features as the AG1000 but with enhanced storage

Boxed In Storage Area

- 4' of boxed in storage area
- Steel deck plating
- Welded on angle 3" angle iron racking
- Swing open, locking gate
- Fork lift accessible
- Perfect fit for mini bulk chemical tank

FEATURES	AG1000	SR1000	AG1250
Frame	2" x 6" tubing 3/16" wall	2" x 6" tubing 1/4" wall with overall length of 24'	2" x 6" tubing 3/16" wall
Liquid System	Accommodates a 1,000 gallon poly drainable leg tank		Accommodates a 1,000 gallon or a 1,250 gallon poly leg tank
Hubs/ Spindles	3600# pound hubs and 2" diameter spindles		4500# pound hubs and 2" diameter spindles
Rims	Standard 8" x 15"		Standard 10" x 15"
Axle Clearance	11" with 11L tires		13" with 12.5L tires
Leaf Spring Suspension	5 leaves, .401" thick by 2" wide		7 leaves, .401" thick by 2" wide
Brakes	N/A		Optional: 2 or 4 wheel surge brakes
GVW	14,000#		16,000#
Options	10" x 15" rims		Misc. tire & rim combinations

DC3000

Dual Liquid Trailer

- 2x 3,000-Gallon Cone Bottom with 15° Slope
- Capacity: 7000 GWR

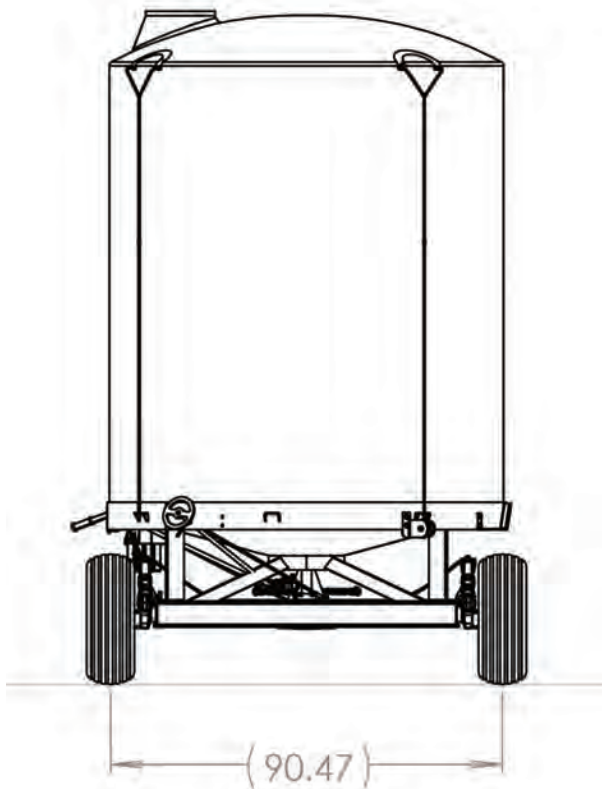
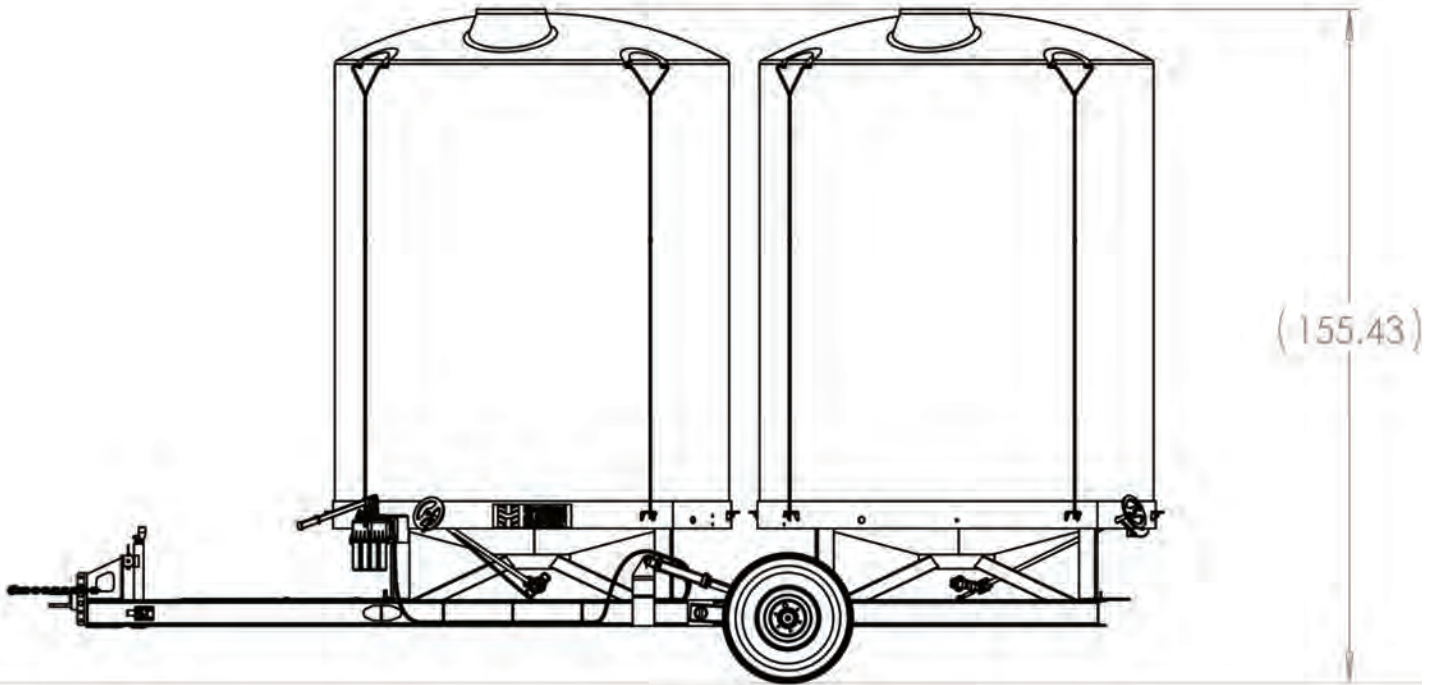

Features

- Frame: 6" x 2" structural steel channel
- Valve Turn Hand Wheel: Optional
- Axle Clearance: 15"
- Finish: 2 component polyurethane black paint

Additional Options

- Bolt-on hose holders
- Fit-N-Forget light kit with reflective tape
- Bolt-on inductor mount plate
- 30-gallon inductor kit with tank and jug rinse
- Tank, pump, hose, and plumbing kits available in 2" or 3"
- Universal wire rope tank tie down kit
- 3" adjustable pintle ring hitch
- 2 5/16 ball hitch



FEATURES	SINGLE – SC1200	DUAL – DC3000	TRIPLE – TC3000
Frame	92" overall width	102" Overall Width	
Liquid System	One 1,200-Gallon Cone Bottom with 15° Slope	Two 3,000-Gallon Cone Bottom with 15° Slope	Three 3,000-Gallon Cone Bottom with 15° Slope
Tires	ST235/80R16E tires	Serviceable stub axles with 11L x 15 Implement Tires	
Suspension	7K tandem highway axles with 5 leaf spring suspension	N/A	
Hitch Type	Front adjustable clevis hitch and towing option with rear drawback hitch		
Safety Chain	3/8" Grade 43 safety chains		
Pump Mount Plate	Standard		
Hydraulic Pump w/ Dual Lift Cylinders	N/A	Standard	
GVWR	14,000#	7000#	
Options	Bolt-on steps with platform and handrail	Bolt-on front force-fill support plate	
	Bolt on fenders	Rigid Tank Tie Down Kit: 2,500 Gallon or 3,000 Gallon	
	Rigid tank tie down Kit	2-5/16" Easy Latch Ball Hitch	
	1200-gallon 15° slope cone tank	3,000-gallon or 2,500-gallon 15° slope cone tank	
	Electric brakes	N/A	

Application isn't just our business. It's our everything.

Heartland AG Systems Equipment is your total solutions provider of application support products and accessories tailored to meet the unique challenges of our industry. As a distributor and a manufacturer, we understand the application business and the importance of high quality, durable equipment that produces reliable application performance. Our industry-leading expertise and experience goes into every product we build:

- Tenders
- Fertilizer Spreaders
- Liquid Trailers
- Liquid Applicators
- Toolbars
- And more



We have your application business covered from every angle.

The Heartland AG Systems Equipment team has been working to make application equipment solutions faster, more reliable and safer since 1965. With complete focus on the application industry, our team works day in and day out to solve your toughest application needs so you can achieve the full potential every season brings.

Efficient

The unique design and engineering of Heartland AG Systems Equipment products delivers a complete portfolio of application solutions, resulting in maximum productivity for superior bottom line performance.

Reliable

With a reputation built on quality and durability, our products are made with heavy-duty performance to handle long days and tough conditions for the uptime your business demands.

Safe

Our advanced safety features were designed to provide better equipment solutions that are safer to operate. Safety is fundamental to a successful operation. Which is why, with everything we manufacture, you and your employees stay top of mind.

Our expertise goes the extra mile.

As the largest Case IH commercial application distributor, we have nine locations across the upper Midwest from which we sell and service our application products.

Ames, IA

DeForest, WI

Garrison, ND

Grand Island, NE

Great Bend, KS

Hutchinson, MN

» *Corporate Office*

» *Manufacturing Plant*

Manvel, ND

Marshall, MO

Mitchell, SD

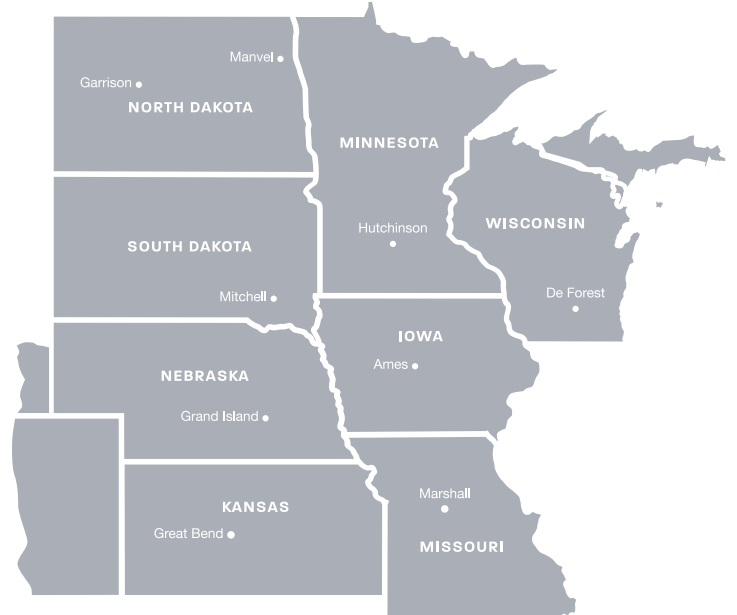

Every day at Heartland AG Systems, our employees commit to solving your toughest application challenges, all while protecting your uptime. This commitment is what enables us to bring the best possible application equipment, products and services to our customers. When you need informed real-time application solutions, we are the only partner you need.





We are application.

HeartlandAG.com
**Corporate Office &
Manufacturing Plant**

1180 MN-7
Hutchinson, MN 55350
(800)-328-5866

Ames, IA
(800) 779-7979

DeForest, WI
(800) 523-2350

Marshall, MO
(800) 889-6161

Grand Island, NE
(800) 445-9110

Great Bend, KS
(800) 652-9290

Manvel, ND
(800) 582-4269

Garrison, ND
(888)483-7669

Mitchell, SD
(800) 995-1943

©2020 Heartland Agriculture, LLC dba Heartland AG Systems.
All Rights Reserved.

