



Heartland
AG SYSTEMS
EQUIPMENT

Liquid Applicators

PRODUCT INFORMATION GUIDE



Liquid Applicators

Models:

6600

6500

6400

6300

6200

Precise application you can depend on.

When it comes to precise delivery and application of liquid fertilizer, don't underestimate the importance of rugged durability. With a complete lineup of pull type liquid applicators, Heartland AG Systems Equipment has you covered. With heavy-duty front mounted toolbars, our products are designed for superior applicator control and visibility to deliver the best across any terrain with industry-leading features engineered to cover more acres faster.

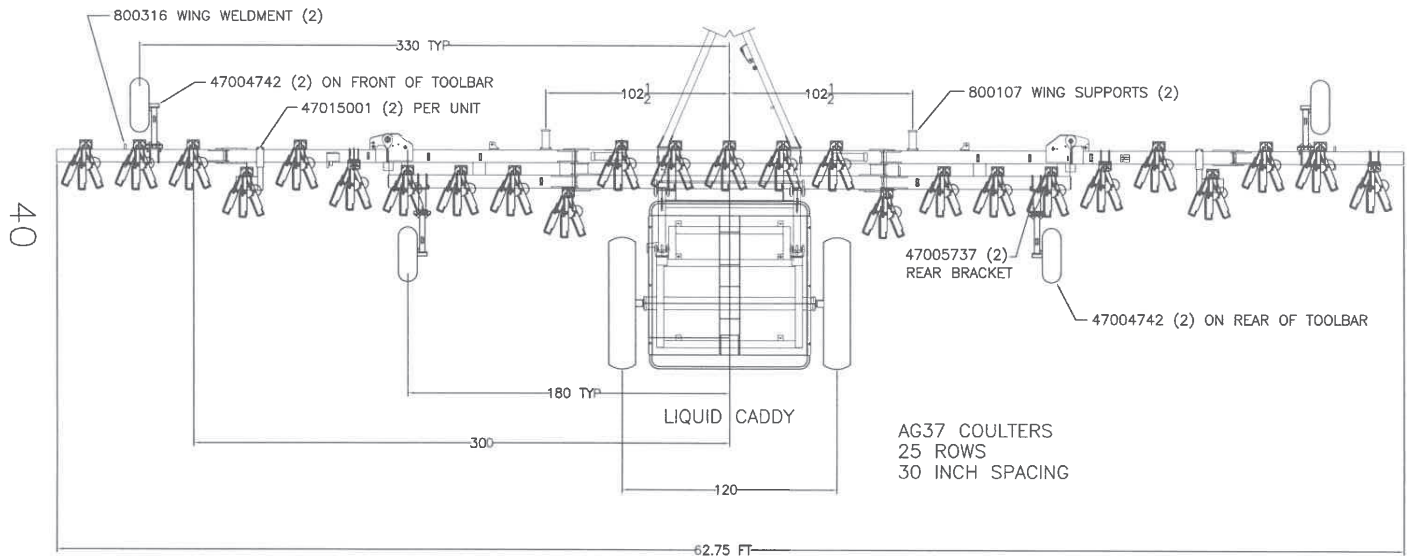



6600 Series

Next level liquid nutrient application.

For high production demands requiring powerful performance, the 6600 is the ultimate upgrade for high efficiency placement and maximum productivity.

- Tri-fold toolbar up to 62' wide
- Heavy duty 7" x 7" x 1/2" wall thickness double toolbar center section
- Covers up to (24) 30" rows
- Comes with either hydraulic pump system with an automatic rate controller or manual set ground drive pump

6500

- Double bar front-mounted toolbar with hydraulic parallel lift
- Extra heavy-duty caddie
- Designed for liquid strip till or hi-pressure 28%

Additional Options

- 2" or 3" force fill package
- 4" remote mount pressure gauges
- 9 gallon fresh water hand rinse tank w/storage compartment
- Warning light package
- Wilger flow monitors for each row

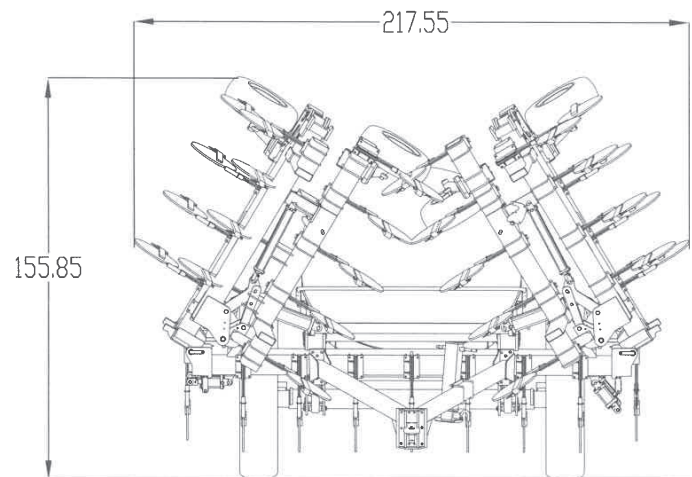



6400 Series



6300 Series

FEATURES	6600	6500
Toolbar	Heavy duty 7" x 7" x 1/2" wall thickness double toolbar center section & primary wings, secondary & outer wings are single bar	Double bar of 4" x 6" x 1/2" heavy wall tubing, center section – wings 3/8" wall
Available Toolbar Widths	Toolbar Lengths up to 62'	Toolbar lengths up to 42'
Center Section	14' 5" center section	13' 6" Center section with toolbar lengths up to 42'
	All hydraulic fold toolbar	
Tank	1,700 Gallon Elliptical Tank	1,300 Gallon Elliptical Tank
Length	17'-2"	Overall length is 15' 3"
Travel Width	18'	18' 8"
Height	13'-4"	12' 6"
Ground Clearance of Frame	34-1/2"	
Adjustable Wheel Track	120" to 144", Optional 144" to 160"	120" to 144"
Tires/Rims	420/80R46 tires on 46 x W12-10 bolt rims, recommended for 30" & 40" rows	380/90 R46 tires mounted on 46 x w12 10-bolt rim
	380/90R46 tires on 46 x W12-10 bolt rims, for 20", 22", 30", & 40" rows-25 rows and under only	
Hubs	Heavy duty 10 on 10" hubs	Heavy duty 10 on 10 hubs
Pump	Single or dual piston pump or hydraulic driven pump with control systems available	
Pole Jack	Heavy duty pole jack	Heavy duty 4" x 4" pole jack swivels out of the way
Clevis Hitch	Adjustable CATIV/V tractor clevis	Adjustable CAT III/IV tractor clevis
Coulter Assembly	AG37 Generation III coulters with 20" blades	Heavy Duty Coulter assemblies
	Stainless steel manifolds & hose	
	Check valves on each row	
Lights		7-pin flashing / warning light kit

6400 Series

Optimized productivity with superior visibility and control.

Enhanced nutrient application with controlled precision placement that is proven reliable for today's tough applying environments.

- Single bar heavy duty front-mounted toolbar
- Great row visibility
- Accurate applicator control

6300 Series

Rugged manufacturing and quality performance.

Durable construction combined with advanced toolbar designs to deliver effective and efficient application across a wide range of field conditions.

- Heavy duty front-mounted toolbar
- Great row visibility
- Accurate applicator control

6400	6300	6200
7" x 7", 1/2" Wall Single bar center section, 3/8" wall wings		Double bar center section of 4" x 6" heavy wall tubing
27.5', 32.5', 37.5' and 42.5'		Available in 26', 30', 35' lengths
13'6" Center section with toolbar lengths up to 42.5'	12" x 6" Wide Center Section	11' center section with toolbar lengths up to 35'
		Hydraulic folding wings and hydraulic lift
1,400 or 1,700 gallon elliptical tanks available	1,000 Gallon Cone tank with 30 degree slope	715 or 1,000 gallon fully drainable leg tank
Hitch to rear plumbing –19'3" with plumbing		20'6" length with plumbing
17'8" with coulters on 30" rows		15'6" with coulters on 30" rows
12'7"		13' – 7"
34"		32 1/2"
120" to 144"		74" to 120"
380/90 R46 tires mounted on a 46 x w12 10-bolt rim	320/85 R38 tires mounted on 38 x w10 8-bolt rim	16.5 x 16.1 implement tires or 385/65R-22.5 tires (required for 1,000-gallon tank)
Heavy duty 10 on 10 hubs	Heavy duty 8 on 8 hubs	
Single or dual piston pump or hydraulic driven pump with control systems available		
Heavy duty 4" x 4" pole jack		Heavy duty 4" x 4" pole jack swivels out of the way
Adjustable CAT III/IV tractor clevis	Patented adjustable tractor clevis	Patented adjustable tractor clevis
		AG 37 Coulter
7-pin flashing / warning light kit		

Toolbars

Models:

3000

7200

8500

Designed to handle the heavy loads and tough terrain of today's application conditions.

Get more with the ability to carry large load capacities, while maintaining the balance needed for smooth, easy pulling and accurate application. Heartland AG Systems Equipment offers a variety of NH₃ toolbars built to perform across a wide range of working conditions. Pre-plant, side-dress, strip-till or zone banding, you get enhanced fertilizer application efficiency combined with heavy-duty durability for maximum return on investment.

3000 Series

The most rugged 3-point toolbar in the industry.

Precise in-field delivery with versatility and low-maintenance construction built to handle a wide variety of application conditions.

- 4" x 6" heavy walled toolbar
- Inline transport for long distance towing
- Built to handle the weight of coulters, disc covers and spring bundled shanks
- Built to adapt to all row spacings

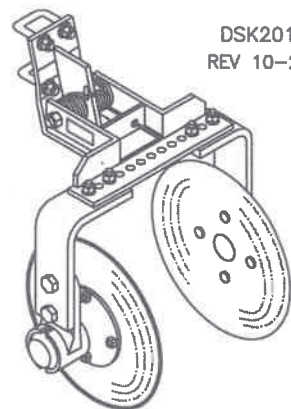

DSK201X13
REV 10-22-09

10-26-07
REV 04-16-12

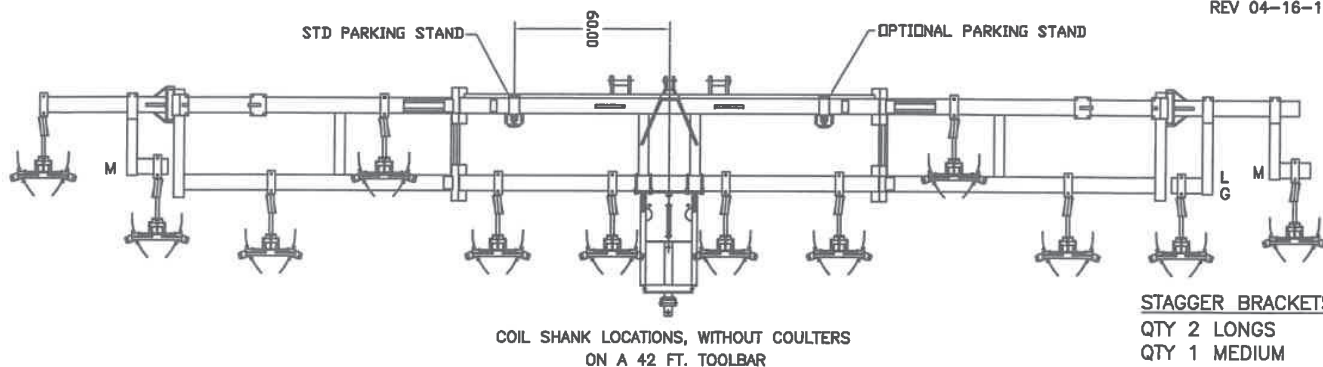



7200

Extreme durability for high capacity application.

Powerful output with long-lasting strength and enhanced features designed to easily endure all the demands of your in-field needs.

- Superior heavy-duty 4" x 6" x 1/2" wall tubing
- Designed to carry the heavy loads of coulters, spring bundles and disc covers
- Built to adapt to most row spacing configurations
- Adjustable walking tandem axles

Additional Options

- 7-pin flashing/warning light kit
- Hydraulic selector valve
- Rolling coulters assemblies
- Single or double spring loaded disc covers
- Meter/Controller assemblies
- Multiple manifolds
- Spring bundle 1" x 2", High Trip Edge Bent, or coil shanks

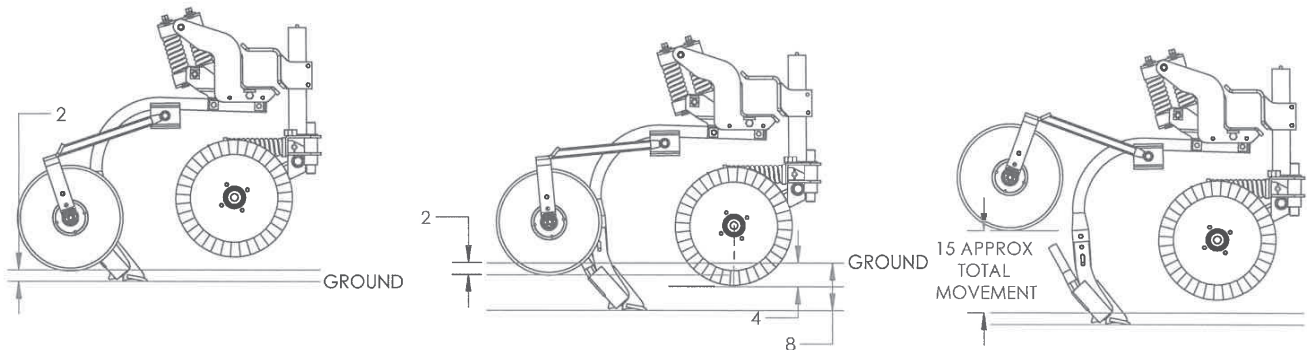



FEATURES	3000	7200	8500
Available Sizes	21', 27', 32, 37.5', 42'	21', 27.5', 29.5', 32.5', 37.5', 40', 42.5'	16.5' Center Section – 40', 50', 55', 60' 19' Center Section – 42.5', 52.5', 60', 62.5'
In Line Transport Pole	3"x 3" tubing 28 ½" long	11'3" long and 7'2" wide 4" x 6" x 3/8" wall	11'5" long and 8'5" wide 4" x 6" x 3/8" wall
Hitch	CAT III 3-point hitch	Patented adjustable CAT III & IV tractor clevis	Patented adjustable CAT III & V clevis
	Rear nurse tank hitch telescopes out 12" and swings a full 30"		
Wing	Primary: Double bar 4"x 6" x 3/8" wall tubing		Primary: Double bar 11' wide, 6"x 6"x 3/8" wall tubing
	Secondary: Single bar 4"x 6"x 3/8" wall tubing. 37' & 42'	Secondary: Double bar 4"x 6"x 3/8" wall tubing flat folding wings	Secondary: Double bar 6" x 6" x 3/8" wall tubing Flat folding wings
Wing Fold	Hydraulic wing folds to 117 degrees		
Center	13'6" wide double bar 4"x 6" x 3/8"	13' 6" wide double bar 4"x 6"x ½"	16.5' or 19' wide double bar 6"x 6"x ½" wall tube
	30" center to center between ranks	38" center to center between ranks	70" center to center between ranks
Tires	Adjustable gauge wheels with 6.70 x 15 tires. Optional 11L x 15 Implement tires	11L x 15 Implement tires on 8" rims	11 x 22.5 Hwty tires and rims 8 ply tires
Transport Height	12' – 10"	13'6" with shanks on 30" rows	15'2" with shanks on 30" rows
Transport Width	19' – 8"	19'2" with shanks on 30" rows	20' 8" with 16'6" center section, 23'3" with 19' center section
Overall Length	8'	19'	22'
Pole Jack		Heavy-duty 4"x 4" pole jack with 10,000 lb. capacity	Heavy-duty 4"x 4" pole jack with 10,000 lb. capacity

GEN III Coulter

Exclusive maintenance-free design.

The Gen 3 coulter has a treated outer coating for added hardness and durability, with installed rulon sleeves on the shafts. This eliminates grease fittings, and lubricates the rocker and swivel shafts, adding to the maintenance-free design of the 7-lip seal and recessed dust cap with O-ring seal. To ensure enhanced performance, these coulters are manufactured to keep grease in and moisture out, eliminating the hassle of daily maintenance and extending application performance.

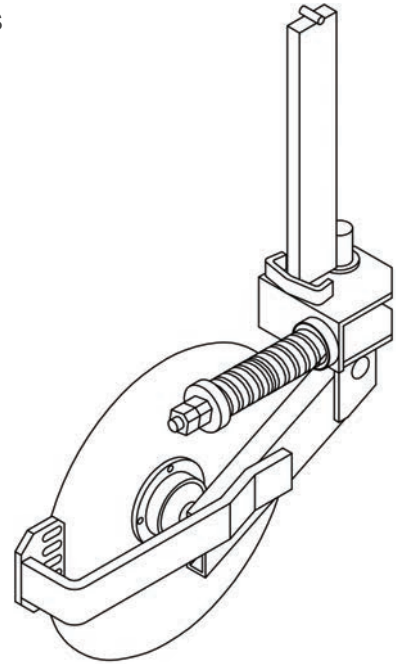

Precision Technology

To deliver the highest quality in precision application, we offer Raven application control products to maximize your equipment investment and operational efficiency.



The Raven Rate Control Module (RCM) is your solution for every season. Control up to five products in one ECU for both liquid and dry applications.



AccuFlow is the most trusted anhydrous ammonia (NH₃) application system on the market—and it earned that trust delivering superior accuracy, simple operation and unrivaled reliability.



The Sidekick Pro direct injection system sets a new standard for chemical applications of every type, with unprecedented precision, savings, and safety.

Application isn't just our business. It's our everything.

Heartland AG Systems Equipment is your total solutions provider of application support products and accessories tailored to meet the unique challenges of our industry. As a distributor and a manufacturer, we understand the application business and the importance of high quality, durable equipment that produces reliable application performance. Our industry-leading expertise and experience goes into every product we build:

- Tenders
- Fertilizer Spreaders
- Liquid Trailers
- 28% Applicators
- Toolbars
- And more



We have your application business covered from every angle.

The Heartland AG Systems Equipment team has been working to make application equipment solutions faster, more reliable and safer since 1965. With complete focus on the application industry, our team works day in and day out to solve your toughest application needs so you can achieve the full potential every season brings.

Efficient

The unique design and engineering of Heartland AG Systems Equipment products delivers a complete portfolio of application solutions, resulting in maximum productivity for superior bottom line performance.

Reliable

With a reputation built on quality and durability, our products are made with heavy-duty performance to handle long days and tough conditions for the uptime your business demands.

Safe

Our advanced safety features were designed to provide better equipment solutions that are safer to operate. Safety is fundamental to a successful operation. Which is why, with everything we manufacture, you and your employees stay top of mind.

Our expertise goes the extra mile.

As the largest Case IH commercial application distributor, we have nine locations across the upper Midwest from which we sell and service our application products.

Ames, IA

DeForest, WI

Garrison, ND

Grand Island, NE

Great Bend, KS

Hutchinson, MN

» *Corporate Office*

» *Manufacturing Plant*

Manvel, ND

Marshall, MO

Mitchell, SD

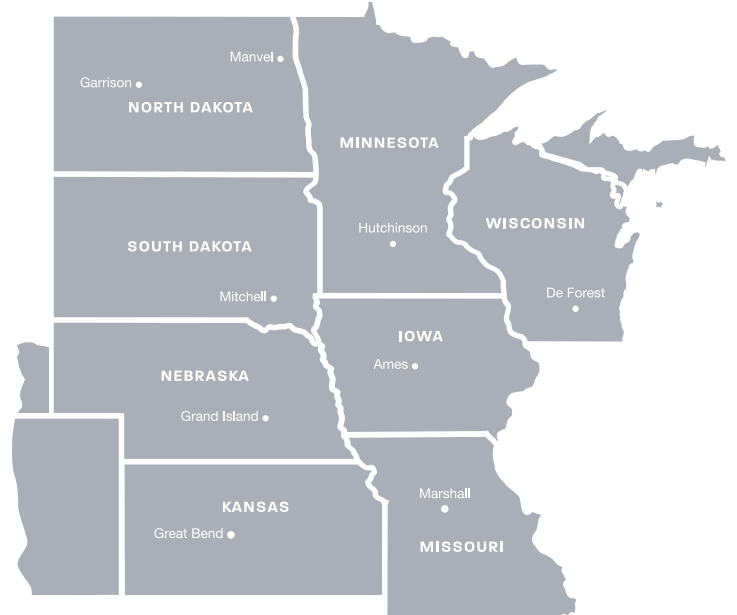

Every day at Heartland AG Systems, our employees commit to solving your toughest application challenges, all while protecting your uptime. This commitment is what enables us to bring the best possible application equipment, products and services to our customers. When you need informed real-time application solutions, we are the only partner you need.





We are application.

HeartlandAG.com

**Corporate Office &
Manufacturing Plant**

1180 MN-7
Hutchinson, MN 55350
(800)-328-5866

Ames, IA

(800) 779-7979

DeForest, WI

(800) 523-2350

Marshall, MO

(800) 889-6161

Grand Island, NE

(800) 445-9110

Great Bend, KS

(800) 652-9290

Manvel, ND

(800) 582-4269

Garrison, ND

(888)483-7669

Mitchell, SD

(800) 995-1943



Heartland AG Systems